

# A HYBRID ENERGY SYSTEM BASED EV CHARGING STATION WITH SOLAR BESS AND DIESEL GENERATOR ALONG WITH ADVANCED CONTROLLER FOR GRID POWER QUALITY REGULATION

<sup>1</sup>Pullapally Uday Kiran, <sup>2</sup>K.Swapna

<sup>1</sup>M.Tech Student, <sup>2</sup>Asst professor

Department Of Electrical & Electronics Engineering

Vidya Jyothi Institute of Technology, Hyderabad

**Abstract** A solar photovoltaic array, battery energy storage, diesel generator, grid-based island, and electric vehicles (EVs) in grid-connected and DG-connected modes are all continuously charged in this article. Battery Charger (CS). The primary function of CS is to charge an EV battery using a solar PV array and BES. The CS will intelligently utilise the energy from the grid or DG set even if the battery is empty and the power of the PV system is not accessible. The power of DG units is constantly pulled to run at 80%–85% load in order to ensure excellent fuel efficiency at all load circumstances. In the absence of a mechanical governor, CS also regulates the voltage and frequency of the generator and accumulator. Additionally, it ensures that even with non-linear loads, the power taken from the mains or DG set has unity power factor. The grid/generator voltage and the common link voltage are synced to provide continuous charging. A fuzzy

logic controller is also used to analyse and reduce overall harmonic distortion on the mains side. CS also oversees active/reactive power transfers from cars to the grid, residences, and other vehicles to increase operational efficiency. There are tools for CS operation analysis and simulation.

**Index Terms**—Diesel generator (DG) set, electric vehicle (EV) charging station, power quality, solar photovoltaic (PV) generation.

## 1. INTRODUCTION

Electric vehicles (EVs) are regarded as one of the most effective modes of transportation due to their minimal exhaust emissions. 3 million electric cars are now in use due to their advantages; by 2030, it is anticipated that this number will reach 100 million. The intended technique, however, would need a sizable infrastructure for electrical supply and charging. Additionally, for electric cars to be

sustainable, the electrical energy required to charge them must originate from renewable and sustainable energy sources. Fossil fuels are used to provide energy, but this only transforms automobiles into power plants rather than reducing their emissions. As a result, producing power from renewable resources may totally cut down on emissions while also being good for the environment. Solar photovoltaic (PV)-based generating is the most practical alternative for EV charging out of all existing renewable energy sources, including solar photovoltaic (PV) systems, wind power, hydroelectric power, and fuel cell-based power. due to the fact that solar energy is often constantly accessible in a city or nation. Indian society has access to it constantly. Wind and water electricity, in contrast to a PV system, are sustainable. While wind power is more favourable along the shore, hydroelectric power is useful in high places. Renewable energy charging stations (CSs) are the most practical option for EV charging, however their integration into the existing charging infrastructure adds a new phase to the energy conversion process, increasing the system's complexity and energy loss. Additionally, every conversion step requires its own controller, which must be integrated with the current controller. In order to manage a range of modes and duties, it is crucial to create an integrated system. Multiple resources must be managed and worked with in concert to accomplish this. The development of CS based on renewable energy is of great importance. Researchers Ugirumurera and Haas looked at how renewable energy may affect the viability of EV CS. Using a high-efficiency bi-directional electric car charger, Chandramouli and colleagues charged electric automobiles using solar energy. The Copyrights @Kalahari Journals

authorised charger, however, is not compatible with AC charging. Montero and other It is advised to connect the PV array to the EV charger using a three-port converter. However, the charger's design does not account for current distortions caused by the mains current. In order to develop a grid-connected EV charger with a PV array, Singh et al. modified the Z source converter. The charger is not meant to be used in isolation, however. Therefore, it does not enable EV charging off-grid. An technique to hybrid optimization was developed by Chaudhary et al. Kineavy and Duffy recommend employing EV CS in conjunction with locally produced PV power for maximum solar PV system usage (under uncertainty) with little grid effect (deployed in a commercial building). Zhang and others A variety of charging methods were used to determine the most effective scheduling of EV CS in the office. In order to provide the best quality of service at the lowest cost and with the least negative influence on the grid, PV-based CS is also suited for on-site usage. The lifespan of a storage battery utilised with a solar PV array system based on commercial buildings was investigated by Kandasamy et al. It is particularly advantageous for EVs because wind-powered CS can run throughout both day and night. This subject is covered in a lot of articles.

Due to the significant quantity of energy stored in their batteries, EVs are currently used as a distributed power source to provide a broad range of utility services. Singh and co. In addition to offering a charging station, a PV array-based CS is presented for vehicle-to-grid (V2G) reactive/active power, active power filtering, and vehicle-to-home operation. A grid-tied PV array system was created

by Saxena et al. for usage in residential and EV applications. An integrated residential PV storage battery system with multimode management for grid-tied and island operation was created by Razmi and Dogou-Mozarrad. According to Erdink et al., Kikusato et al., and Hafiz et al. research, EVs may be employed for commercial purposes to conduct vehicle-to-home and vehicle-to-grid operations for utility and client advantage. Research on renewable energy-based CS has generally concentrated on optimising a number of loading characteristics, including B. the quantity of renewable energy resources, storage amount, driving style of the vehicle, time needed for charging, charging cost, and charging time. Only a few papers, nevertheless, have really used CS to use renewable energy sources. Additionally, in reality, the impact of CS is often overlooked. Additionally, a significant portion of research solely takes into account how well CS performs in grid-tied mode or island mode. The PV module's peculiar manner of operation—mains connection—makes it useless even in sunshine (solar radiation). Sporadic solar radiation also has an impact on PV production in discrete operation. To lessen the impacts of fluctuating solar radiation, an accumulator is needed. Maximum power point tracking has to be turned off when the battery is completely charged in order to prevent overcharging. The CS is supported in this article by a DG set, grid, energy storage device, and solar panel array. These parts function in island mode, grid-tied mode, or DG-set connected mode to optimise the electricity generated by the PV array under all operating situations. Several publications also analyse grid tide and island modes. Even though these two modes are independently managed, mode change may happen automatically.

Copyrights @Kalahari Journals

As a consequence, the PV array electricity must be shut off, and the EV cannot continue charging in the absence of an automated mode switch. The automated mode switching logic described in this article enables the controller to transition between a number of operating modes in accordance with the output power of the PV array and the demand for EV charging. A backup battery is used in conjunction with a PV generator to guarantee the continuous and dependable functioning of CS due to the intermittent nature of the PV generator and lack of availability throughout the night. However, continuous backup is impractical because of the accumulator's small capacity. As a result, when both energy storage and PV array power are missing, CS needs grid backup. There may be a need for a DG set to guarantee that charging continues because to the restricted network accessibility, particularly in distant locations.

However, a DG set's utilisation is constrained and its performance is impacted by the type of the load. Only a small number of harmonics in the load current are often permitted by DG set design [ ]. Due to the harmonic character of EV current and the frequent usage of power factor correction circuits and rectifiers prior to DC/DC converters by EV chargers for buck conversion, EV charging has a negative impact on the performance of DG systems. The EV charger (VSC) harmonics and reactive power needs may be handled by the voltage source converter explained in this article, ensuring that the DG set is always charged to at least 80% of its nominal value. The article's key ideas are outlined in the list below.

1) Creation and testing of an integrated CS that enables both grid-based and electric car AC and DC

Vol.7 No.12 (December, 2022)

charging. This CS is made up of a DG set, a PV system, and an energy storage system.

2) Create a single controller with just a single VSC and no hardware changes that enables operation in the CS island, interconnected, and DG set-connect modes.

Simple mode switches and continuous loading are made possible by the development of mode switching logic based on CS.

4) Creating a control strategy to support the grid and transmit electricity from one vehicle to another (V2G or V2V).

5) CS functions as an active power filter to remove line harmonic currents and guarantee power exchange at unity power factor. This is necessary for CS to adhere to IEEE 519.

6) A technique for managing a DG set's voltage and frequency without the need of a mechanical automatic voltage regulator.

7) Technology that sends extra power produced by the PV panels to the grid in order to prevent overcharging the storage battery.

## 2. SYSTEM DESCRIPTION

The proposed CS uses a solar PV array, a storage battery, a DG set, and grid energy to power the load connected to the CS and to charge the EV, as illustrated in Fig.5.1. The solar PV array is connected to the VSC's dc link through a boost converter, and a storage battery is connected directly to the same connection. A single phase self-excited induction generator (SEIG), an electric

vehicle (EV), and a nonlinear load are connected via the VSC's ac side.

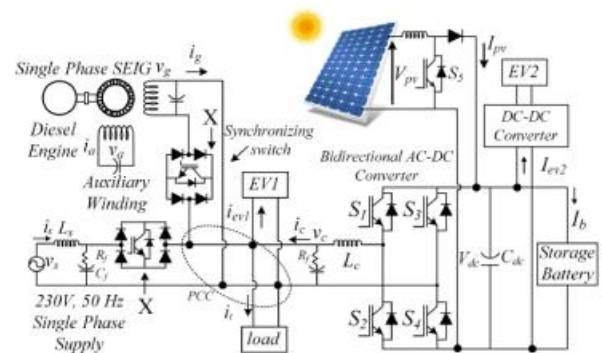

**Fig. Topology of a CS.**

a coupling inductor By using a ripple filter at the point of common coupling (PCC) to eliminate switching harmonics, grid and generator currents are rendered sinusoidal. A capacitor used for excitation is connected to the SEIG's auxiliary winding. A small capacitor is also connected across the main winding of the SEIG. A synchronising switch is used between the grid/DG set and PCC to control the controlled connection and disconnection of the CS to the grid/DG set.

## 3. STRATEGIES FOR MANAGEMENT

Here, a number of control methods used in the CS are investigated. A. Islanded mode of the VSC control (Absence of DG Set and Grid) The CS's islanded control ensures its consistent operation in the absence of the grid, maintaining both the continuous generation of solar power and the ac and dc charging of EVs. Without making many adjustments to the control, the storage battery can regulate the solar PV production and dc charging. The ac charging, however, needs a separate controller for the VSC, which is utilised to provide the local voltage reference, since there is no voltage

reference available without the grid. The islanded controller offers an internal voltage reference of 230 V and 50 Hz thanks to the logic shown in Fig. 5.2, which combines frequency and passes through the sine to generate the reference voltage. The reference converter current is calculated by comparing the output reference to the converter's terminal voltage after the voltage error has been minimised using a proportional integral (PI) controller. Current generation and error reduction reference values are provided as

$$i_c^*(s) = i_c^*(s-1) + z_{pv} \{v_{ce}(s) - v_{ce}(s-1)\} + z_{iv} v_{ce}(s).$$

The reference current, after being compared to the measured converter current and passing through a hysteresis controller, generates the converter's gate signals.

**B. Control of the VSC in DG set or grid-connected mode** In grid-connected mode, the controller's responsibility is to decide how much power will be traded with the grid. When connected, DG sets operate in continuous power mode for the most efficient use of fuel. However, in all scenarios, the controller has to compensate for the EVs' demands for reactive and harmonic current. In order to achieve this, it calculates the reference current for the grid or DG set using the EV current. When determining the reference current in a grid-connected scenario, only the active current of the EV current is taken into consideration. On the other hand, in the DG set connected mode, the reference DG set current is estimated using both the active and reactive currents of the EV. In this work, an adaptive notch cancellation (ANC) is used to derive the fundamental frequency current of the EV [22].

Together with the sample and hold logic, the fundamental current at each zero crossing of the quadrature and in-phase unit templates produces the active and reactive currents, respectively. The total active and reactive currents in grid connected mode are now as follows:

$$I_{sp} = I_p - I_{ef2} - I_{pf}$$

$$I_{sq} = 0.$$

In order to function at unity power factor, only the EV's active current is considered in the grid-connected mode, and the reactive current is set to zero. However, when the DG set is connected, both the active and reactive current components of the EV are used. The total active and reactive currents of a DG set in linked mode are as follows:

$$I_{sp} = I_p - I_{ef2} - I_{fp} - I_{pf}$$

$$I_{sq} = I_{vq} - I_q$$

where  $I_p$  and  $I_q$  are the active and reactive currents of the EV, respectively, and  $I_{ef2}$  and  $I_{pf}$  are the feed-forward terms of the EV2 and the PV array.  $I_{fp}$  and  $I_{vq}$  are the models numbers for the voltage and frequency regulators used in the DG set connected mode.  $I_{ef2}$  controls how much electricity is sent from the electric car to the grid. The feed-forward term, or  $I_{pf}$ , for grid-connected PV arrays controls overcharging of the storage battery. Since the energy storage is directly interfaced to the dc connector, the storage battery cannot be charged in the CC/CV mode. The storage battery can, however, always be guaranteed not to be overcharged. Overcharging is avoided when a storage battery is connected to the grid by feeding the grid with solar PV power. This is accomplished by include the solar PV array feed-forward term in

the grid linked mode control, as shown in Fig. 5.2. The amount of PV array power that is sent into the grid is determined by multiplying the feed-forward term by a variable gain, "k". The 0 to 1 range for constant "k" is determined by the storage battery's SOC statistics. As a result, "k" takes "1" when the storage battery is completely charged. However, when the battery is completely depleted, "k" turns into "0." For a grid or DG set, the estimated reference current is as follows:

$$i_s^* \text{ or } i_g^* = I_{tp} \times u_p + I_{tq} \times u_q$$

Here are the up and qp (vg or vs) primary voltage synchronisation signals for the DG set. A hysteresis controller creates switching signals using the measured and reference currents of the grid/DG set, as illustrated in Fig. 5.2.

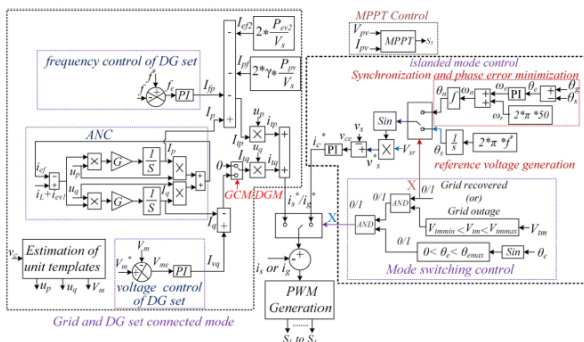

**Fig. Unified control of the VSC for standalone and grid and DG set connected mode”.**

C. DG Set Voltage and Frequency Control For single-point operation, discrete control of VSC regulates the voltage and frequency of DG sets. Reactive power modifies the voltage in a decoupled control system, while active power modifies the frequency. Therefore, voltage and frequency are controlled by two PI controllers. It is shown as a PI controller for voltage control.

$$I_{vq}(s) = I_{vq}(s - 1) + z_{vp}\{V_{me}(s) - V_{me}(s - 1)\} + z_{vi}V_{me}(s)$$

Where Vme is equal to Vm Vm and zvi and zvp are the PI controller's gains. Similar to this, the discrete equation for a frequency PI controller is as follows:

$$I_{fp}(s) = I_{fp}(s - 1) + z_{fp}\{f_e(s) - f_e(s - 1)\} + z_{fi}f_e(s)$$

Grid-tied control is achieved by combining the outputs of the voltage and frequency regulators, as shown in figure 2, where fe is the frequency error and zkfp and zfi are the PI gains. In grid-tied mode, these regulators' outputs are zero, but the grid's voltage and frequency are still controlled. D. EV2 EVs linked through a DC/DC converter employ CC/CV regulation, or constant current/constant voltage. Until the battery's terminal voltage reaches the fully charged state voltage, the EV charges in CC mode. However, charging is shifted to CV mode when EVs in virtually full state of charge attain the necessary terminal voltage. The CC/CV charging procedure is managed by two PI controllers, as shown in Figure 5. 3. The reference current for the current control stage is provided by the outside voltage loop.

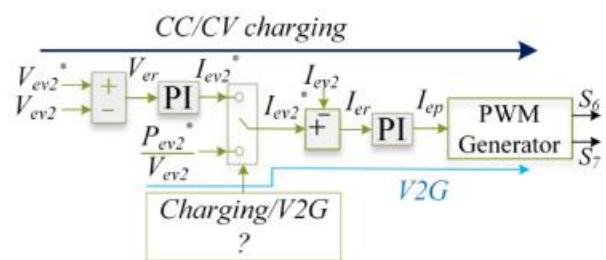

**Fig.. “EV2 control for CC/CV charging and V2G power transfer”.**

where Zevp, Zev, and Ver are the controller gains and Ver is the EV battery voltage error. Using the

reference and measured battery currents as inputs, a pulse width modulation generator and PI controller provide switching signals for the converter. syntax for calculating duty cycle in a PI controller

$$d_{ev}(s) = d_{ev}(s - 1) + z_{ep}\{I_{er}(s) - I_{er}(s - 1)\} + z_{ei}I_{er}(s)$$

$I_{er}$  is the battery current error,  $z_{ep}$  and  $z_{ei}$  are the controller gains, and  $3$  is the reference power in Figure 5. The EV2 battery is depleted for V2G power transfer using the reference power, and the controller makes the detour illustrated in Figure 5. The feed forward term is controlled by EV2. 3. E. Control of synchronisation and switching Since the CS may function in many modes depending on the load and generation needs, a mode change system must be established. By doing this, you can make sure that changing between modes is seamless and has no negative effects on charging. A mode switching mechanism is created for these circumstances including connections from islands to networks and DG sets. With this method, the controller synchronises the voltages after first determining the phase difference between the two. Using the logic shown in FIG., the PI controller modulates the frequency of the voltage produced by the VSC in an islanded condition. Lower in step 2. proposed PI controller

$$\Delta\omega(s) = \Delta\omega(s - 1) + z_{pa}\{\Delta\theta(s) - \Delta\theta(s - 1)\} + z_{ia}\Delta\theta(s)$$

Here, the phase difference,  $z_{pa}$ , and  $z_{ia}$  serve as the tuning parameters for the controller. Figure 5.2 also depicts situations when CS runs in island mode and situations that call for mode switching. When all

sync requirements are satisfied, the control logic produces a sync switch enable signal,  $X="1"$ .

#### 4. MATLAB & SIMULATION RESULTS

##### A. SIMULATION CIRCUITS

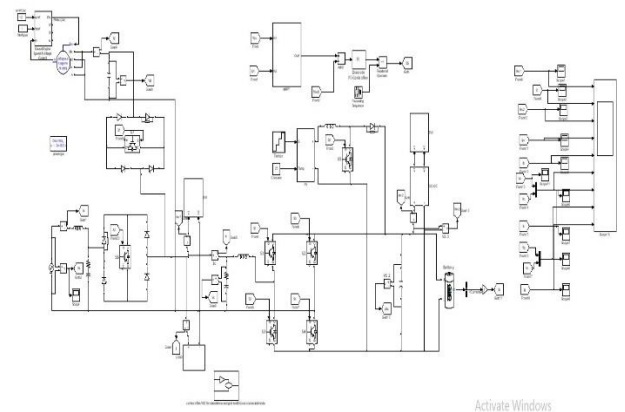
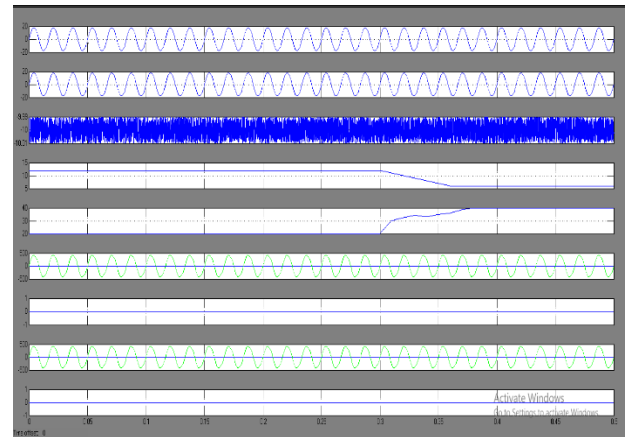

Fig Simulink circuit

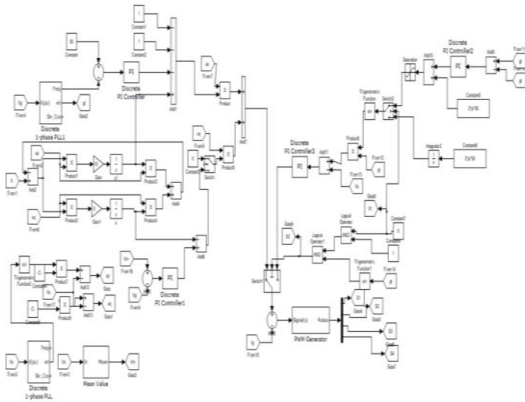

Fig Simulink controller circuit

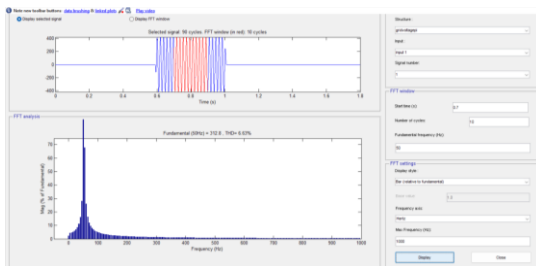

Fig thd using pi

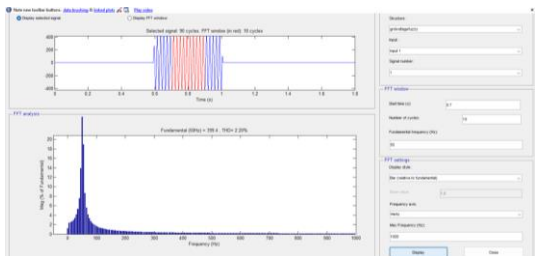

Fig thd using fuzzy

## 5. CONCLUSION

For EV charging, the PV array, storage battery, grid, and DG sets-based CS are all finished. The findings reported here demonstrate that CS can function in a variety of modes, including islanding, grid connection, and DG-set connectivity, using a single VSC. Additionally, test findings have shown that the EVs function admirably under a variety of

steady-state circumstances, as well as dynamic circumstances brought on by changes in solar radiation, the current utilised to charge EVs, and load. The ANC-based control algorithm can manage the UPF or optimum loading of the DG-set, as shown by the test results with the DG-set or in grid-tied mode, while the given results proved that the CS can be handled independently. excellent voltage quality generator. The potential of operating the PV array at its maximum power point (MPP) and having the DG-set loaded to its optimum level is further increased by islanded, grid-tied, and DG-set-tied operation as well as automated mode switching. dependability of charging has increased. The controller is effective since CS always operates with voltage and current THD  $\leq 5\%$ , in accordance with IEEE standards. The information above demonstrates that, even with the present controller, this CS is capable of making the best use of a variety of power sources while offering reliable and effective charging for EVs.

## 6. REFERENCES

- [1] International Energy Agency, “Global EV Outlook 2018— Towards crossmodal electrification,”2018.[Online]Available:[https://webstore.iea.org/download/direct/1045?fileName=Global\\_EV\\_Outlook\\_2018.pdf](https://webstore.iea.org/download/direct/1045?fileName=Global_EV_Outlook_2018.pdf)
- [2] International Energy Agency, “Renewables 2018—Analysis and Forecasts to 2023,\*\* 2018.[Online].Available:<https://webstore.iea.org/download/summary/2312?fileName=English-Renewables-2018ES.pdf>
- [3] J. Ugirumurera and Z. J. Haas, “Optimal capacity sizing for completely green charging



systems for electric vehicles,” *IEEE Trans. Transp. Electrification*, vol. 3, no. 3, pp. 565–577, Sep. 2017.

[4] G. R. Chandra Mouli, J. Schijffelen, M. van den Heuvel, M. Kardolus, and P. Bauer, “A 10 kW solar-powered bidirectional EV charger compatible with chademo and COMBO,” *IEEE Trans. Power Electron.*, vol. 34, no. 2, pp. 1082–1098, Feb. 2019.

[5] V. Monteiro, J. G. Pinto, and J. L. Afonso, “Experimental validation of a three-port integrated topology to interface electric vehicles and renewables with the electrical grid,” *IEEE Trans. Ind. Inform.*, vol. 14, no. 6, pp. 2364–2374, Jun. 2018.

[6] S. A. Singh, G. Carli, N. A. Azeez, and S. S. Williamson, “Modeling, design, control, and implementation of a modified Z-source integrated PV/Grid/EV DC charger/inverter,” *IEEE Trans. Ind. Electron.*, vol. 65, no. 6, pp. 5213–5220, Jun. 2018.

[7] K. Chaudhari, A. Ukil, K. N. Kumar, U. Manandhar, and S. K. Kollimalla, “Hybrid optimization for economic deployment of ESS in PV-integrated EV charging stations,” *IEEE Trans. Ind. Inform.*, vol. 14, no. 1, pp. 106–116, Jan. 2018.

[8] F. Kineavy and M. Duffy, “Modelling and design of electric vehicle charging systems that include on-site renewable energy sources,” in *Proc. IEEE 5th Int. Symp. Power Electron. Distrib. Gener. Syst.*, 2014, pp. 1–8.

[9] Y. Zhang, P. You, and L. Cai, “Optimal charging scheduling by pricing for EV charging station with dual charging modes,” *IEEE Trans. Intell. Transp. Syst.*, vol. 20, no. 9, pp. 3386–3396, Sep. 2019.

[10] Y. Yang, Q. Jia, G. Deconinck, X. Guan, Z. Qiu, and Z. Hu, “Distributed coordination of EV charging with renewable energy in a microgrid of buildings,” *IEEE Trans. Smart Grid*, vol. 9, no. 6, pp. 6253–6264, Nov. 2018.

## AUTHOR'S PROFILE



**Mr. Pullapally Uday Kiran** received his B.Tech from Siddhartha Institute of Engineering and Technology, Hyderabad in 2020. Presently he is pursuing M.Tech in Vidya Jyothi Institute of Technology, Hyderabad. His areas of interest are Power Systems, Power Quality.

EmailId- [udaykiran.1129@gmail.com](mailto:udaykiran.1129@gmail.com)



**K. Swapna** is presently working as Asst. Professor in Vidya Jyothi Institute of Technology, Hyderabad, India. She completed her M. Tech from St. Mary Institute of Technology, Hyderabad. B. Tech from Khader Memorial College of Engineering & Technology, Nalgonda. The areas of interest are FACTS, Advances in Power Systems, Power Electronics and Electrical Machines

EmailId-

[swapnak@vjit.ac.in](mailto:swapnak@vjit.ac.in)